

SWIM STIRRUP®

INSTALLATION INSTRUCTIONS

The **Swim Stirrup®** has been carefully engineered to provide safe, easy access to small boats for swimmers or water skiers. Proper installation and use will assure years of dependable service. Read through these instructions **completely** before beginning installation.

INSTALLING THE DECK CLEAT

The Swim Stirrup's deck cleat is the critical point of attachment between the stirrup and your boat, and must be mounted properly to insure safe use of the device. Choose a location on the boat that is **away from the motor** and where a person entering the boat won't interfere with boat equipment or hardware. Here are some suggestions:

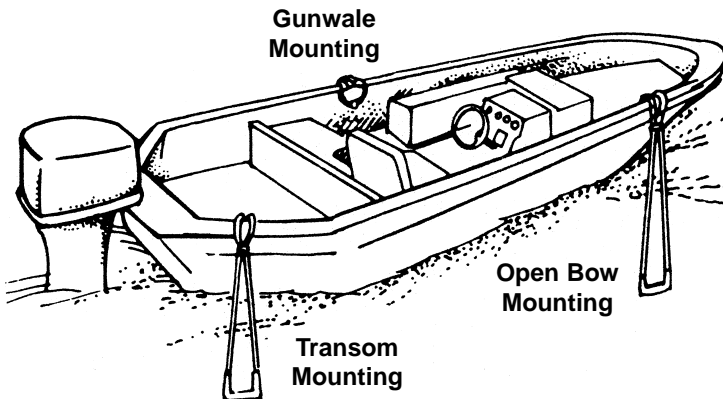

Make sure the cleat is mounted to a surface which can handle the load of an entering swimmer. The maximum weight Swim Stirrup is designed to support is 300 lbs. (136 kg).

The cleat may be mounted either inside, outside, or on top of the gunwale. **Note that the cleat's retaining ring must always point toward the inside of the boat.**

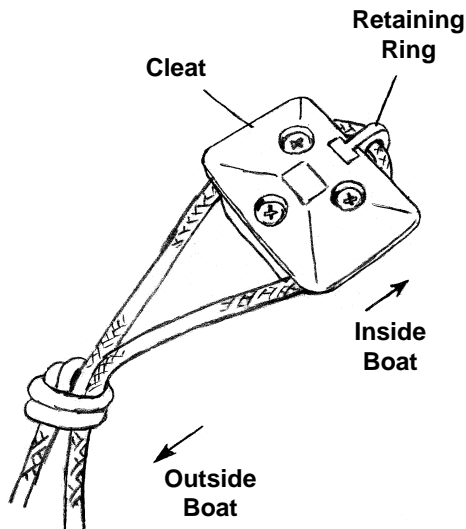

The ring prevents the rope from slipping off the cleat when the Swim Stirrup is bounced by waves. It also holds the rope in place when stored inside the boat between uses. The ring is **NOT** designed to support much weight—when pointed toward the inside of the boat, the cleat will handle the load.

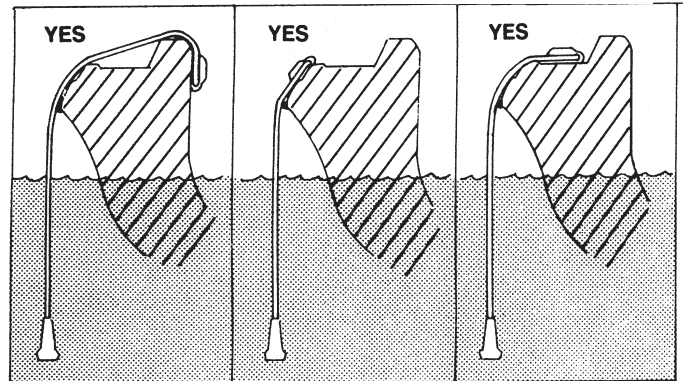

Proper Cleat Orientation:
cleat bearing the load.

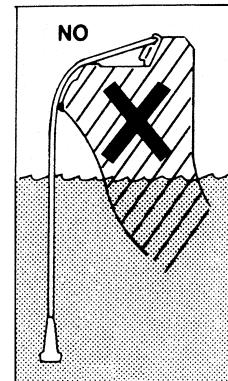

Improper Cleat Orientation:
retaining ring bearing the load.

Follow this procedure for cleat installation:

1. Position the deck cleat on a flat surface with the ring pointing toward the inside of the boat.
2. Use a pencil to mark the center of the three holes for drilling.
3. Drill pilot holes **using 1/16" (1.6 mm) bit or smaller**, making sure the drill is held perpendicular to the mounting surface.
4. Double-check the position of the pilot holes using the cleat; redrill if necessary.

Continued...

5. For most fiberglass or wood boats, follow the pilot holes using a 3/16" (4.8 mm) drill and use the three 1 1/4 x 1/4 (3.2 x .65 cm) pan-head screws provided to securely attach cleat to gunwale.

For aluminum or thin-wall boats, do not use the pan-head screws, as their length may cause them to protrude dangerously. Instead, use 1 1/4 x 1/4 (3.2 x .65 cm) pan-head bolts, fender washers, and retaining nuts to mount. These may be purchased from your nearest hardware store.

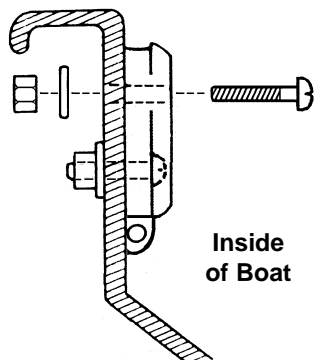

FINAL ASSEMBLY

With the deck cleat properly installed, you can now complete the Swim Stirrup assembly:

1. Run the rope around the deck cleat and through the retaining ring so both ends hang over the side of the boat and are of equal lengths.
2. Grab both strands of rope about one foot (0.3 meter) down from the cleat in one hand; use the other hand to remove the retaining ring and loop of rope from the deck cleat.

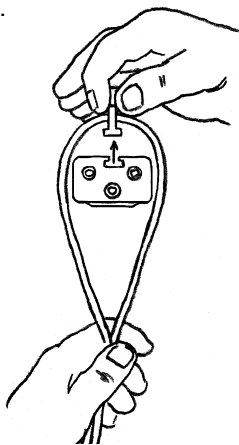

3. Tie an overhand knot in the looped section of the rope, leaving a loop approximately six inches (15 cm) long holding the retaining ring.

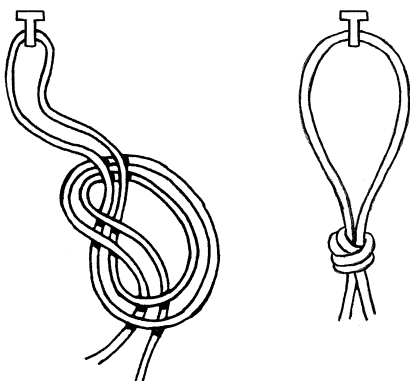

4. Slip the retaining ring back into its slot in the cleat and trap the rope under the cleat on both sides.

5. Slip the ends of the rope through the towers of the Swim Stirrup and tie a knot at each end approximately six inches (15 cm) below the bottom of the side of the boat.

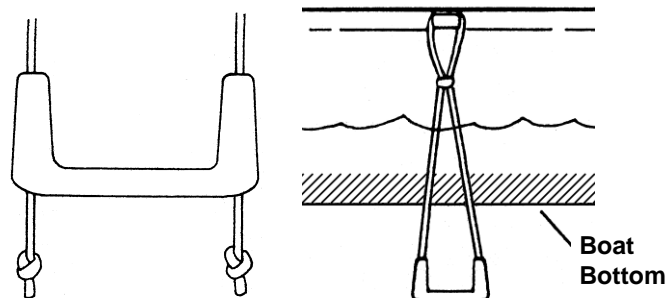

6. Adjust knots as necessary to stirrup height that works best on your boat. Once you've determined the proper height, cut off the excess rope one or two inches (2.5 to 5.0 cm) below the knots for a neater appearance. The rope should be dry before cutting. Use a match to melt together the ends of the fibers to prevent fraying.

USING THE SWIM STIRRUP

1. Make certain that the rope is completely around the deck cleat before use. Attempting to use the Swim Stirrup while attached only to the retaining ring can result in sudden failure and potential injury.
2. Swim Stirrup should **ONLY** be used **when the boat is in the water and the motor is turned off**. Be sure to pull the stirrup into the boat when you get underway to avoid possible hazards.
3. Use the Swim Stirrup by grasping it as you swim alongside the boat. Pull it down and **insert one foot, grasping the gunwale with both hands**. Stand straight up on the stirrup and swing your free leg over the gunwale. It's that easy.
4. Periodically check the condition of the hollow braided rope on your Swim Stirrup for wear or fraying sometimes caused by heavy use. Should any wear be evident, simply replace the rope with any standard 5/16" (8 mm) hollow braided polypropylene or polyethylene line.

Swim Stirrup should be used only as a boarding device for shallow draft boats, and is NOT intended to be used as a tow rope or boarding device for larger boats. Swim Stirrup should not be used outside the water for ANY reason.

ONE-YEAR WARRANTY

We warrant our products to be free of defects in material and workmanship for one year from the date of original purchase. Write for full warranty details.

Davis Instruments

3465 Diablo Avenue, Hayward, CA 94545, U.S.A.
Phone (510) 732-9229 • Fax (510) 732-9188
info@davisnet.com • www.davisnet.com